

Performance Analysis of High-Efficiency and Compact Heat Exchanger Using Environment-Friendly Refrigerant

Yuki Takahashi^{*}, Hoheum Cho^{**}, Daisuke Jige^{***}, Norihiro Inoue^{***}

^{*}School of Tokyo University of Marine Science and Technology, 2-1-6 Etchujima, Koto-ku, Tokyo 135-8533, Japan

^{**} Graduate School of Marine Science and Technology, Tokyo University of Marine Science and Technology, 2-1-6 Etchujima, Koto-ku, Tokyo 135-8533, Japan

^{***}Tokyo University of Marine Science and Technology, 2-1-6 Etchujima, Koto-ku, Tokyo 135-8533, Japan

Abstract. *Over the years, high-performance and energy-efficient onboard equipment has been developed; however, most of the waste heat at low temperatures level is lost from marine vessels, discharging carbon dioxide. In marine engineering, with a small heat exchanger, high-efficiency and environment-friendly refrigerants are needed to prevent global warming and to use energy effectively. This study experimentally investigated the two-phase flow characteristics and void fraction of an environment-friendly refrigerant in a narrow rectangular channel imitating a plate heat exchanger and the influence of the flow characteristics on the performance of the heat exchanger.*

Key words: *Heat exchanger, Refrigerant, Narrow channel, Two-phase flow, Void fraction*

1 Introduction

The research theme of the Energy Conversion Laboratory is environmental conservation technology related to energy saving and improvements in the performance of element equipment, mainly heat exchangers in the field of refrigeration air-conditioning engineering for general

households and onboard environments.

Owing to globalization and growth in the marine transport industry, the total amount of carbon dioxide emissions from ships has been increasing. Over the years, various types of high-performance and energy-efficient onboard equipment have been developed; however, most of the waste heat at low temperature is lost from marine vessels, and discharged as carbon dioxide.

A binary power generation system, which uses working fluids with a low boiling point, such as fluorocarbons, as a low-medium temperature heat source, has attracted the attention of researchers. Low-boiling-point fluids are considered next-generation working fluids owing to their effective use of low-temperature waste heat.

In marine engineering, a plate heat exchanger composed of narrow passages has received significant attention because it can be miniaturized and uses waste heat effectively. A plate heat exchanger is a type of heat exchanger that uses metal plates to transfer heat between two fluids. It has four advantages: high efficiency, energy saving, miniaturization, and maintainability. The size of the air-conditioning system used on a ship needs to be minimized owing to the spatial limitations of marine structures. Hence, the development of high-performance and compact heat exchangers, such as a plate heat exchanger composed of narrow passages, is required for improving the performance, reducing the charge amount of the refrigerant, and minimizing the space requirements.

Over the years, fluorocarbons have been used as a refrigerant. Fluorocarbons are nontoxic, incombustible, stable, and easy to liquefy, and can be classified into three types: chlorofluorocarbons (CFCs), hydrochlorofluorocarbons (HCFCs), and hydrofluorocarbons (HFCs). CFCs and HCFCs contain chlorine, which acts as an ozone-depleting substance. Through the Montreal Protocol in 1987, it was decided that the production and consumption of ozone-depleting substances should be regulated. In 2010, CFCs were completely abolished all over the world; in addition, HCFCs will be abolished by 2020 in developed countries, and by 2030 in developing nations. Under this protocol, HFCs have been promoted as a substitute for CFCs and HCFCs. On the other hand, because HFCs do not contain chlorine, they are used for domestic air conditioners. Although they do not impact the ozone, the greenhouse effect from HFCs is several hundred to four thousand times greater than that of carbon dioxide. For this reason, in 2016, HFCs became a regulated material. The Kigali amendment requires an 85% reduction of HFCs by 2036 in developed countries, and by 2047 in developing nations. Large-scale refrigerators use the refrigerant R134a, which is a type of HFC. As an alternative, R1234ze(E) has been suggested because it does not destroy the ozone and its greenhouse effect is much lower than that of R134a. Thus, the use of this environmentally friendly refrigerant will continue to spread.

However, studies on plate heat exchangers using a next-generation refrigerant as a test fluid have

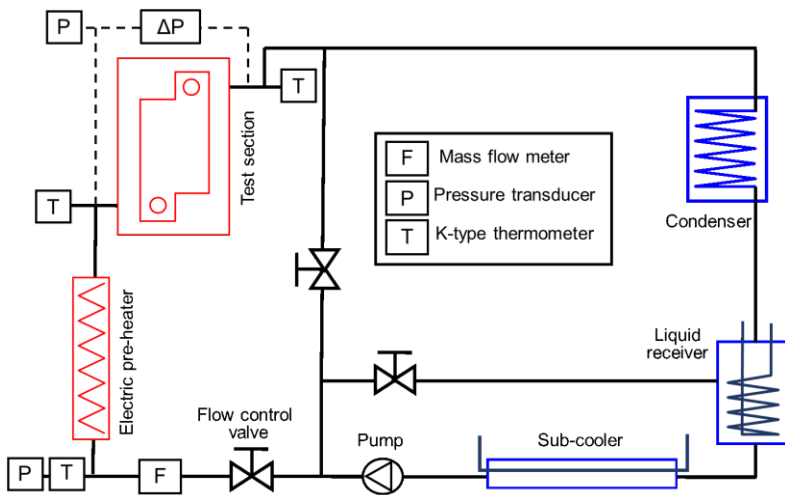

Fig. 1 Schematic of experimental apparatus

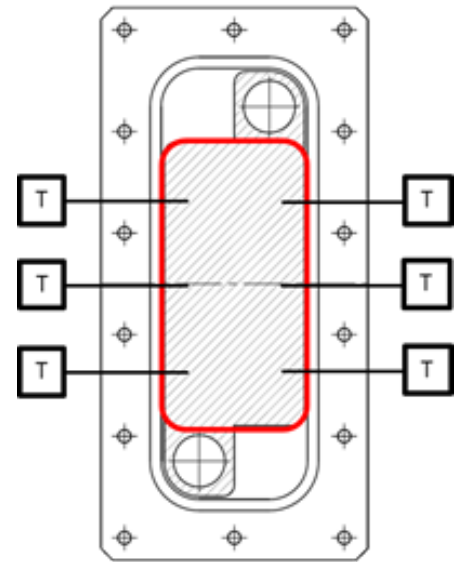

Fig. 2 Schematic of test section

been limited. The present study experimentally investigates the two-phase flow characteristics and void fraction of an environmentally friendly refrigerant, R1234ze(E), in a narrow rectangular channel imitating a plate heat exchanger, and the influence of the flow characteristics on the performance of the heat exchanger.

2 Experiment Apparatus and Procedure

2.1 Experiment Apparatus

The experiment apparatus consists of a main loop and a bypass loop, as shown Fig. 1. The main loop consists of a pump, flow control valve, Coriolis mass flow meter, electric preheater, test section, condenser, receiver, and super-cooler. The test refrigerant pumped by the pump is adjusted to a predetermined quality in the electric preheater and flows into the test section. The refrigerant then returns to the pump through the condenser and receiver.

Fig. 2 shows an outline of the test section, which is made of a stainless sheet with a total length of 234 mm and a width of 114 mm. The test channel is a narrow rectangular channel with a depth of 0.5 mm, a width of 60 mm, and a length of 180 mm. The upper part of the flow channel is covered with glass to observe the flow patterns. The temperature and pressure of the test refrigerant at the inlet and outlet of the test section are measured using K-type sheath thermocouples, as well as an absolute pressure transducer and a differential pressure transducer. The wall temperature in the test channel is measured using K-type sheath thermocouples, as shown Fig. 2.

2.2 Experiment Procedure

Table 1 Experimental conditions

Test refrigerant	R1234ze(E)
Saturation temperature [°C]	15
Mass velocity [kgm ⁻² s ⁻¹]	100, 200
Vapor quality [-]	0.05 – 0.9

Table 1 shows the experiment conditions. The experiments were carried out using R1234ze(E) as the test refrigerant at mass velocities of 100 and 200 kgm⁻²s⁻¹ and a vapor quality of 0.05 to 0.9 at a saturation temperature of 15 °C. The part surrounded by the red line in Fig. 2 was filmed using a high-speed camera to observe the flow patterns. The void fraction was determined through an image analysis of a randomly chosen image frame taken by the high-speed camera.

3 Data Reduction

The superficial velocities of the gas and liquid J_G and J_L are defined below:

$$J_g = \frac{Gx}{\rho_G}, \quad (1)$$

$$J_L = \frac{G(1-x)}{\rho_L}, \quad (2)$$

where G is the mass velocity, x is the vapor quality, and ρ_G and ρ_L are the densities of the gas and liquid phases. The properties of R1234ze(E) were obtained from REFPROP ver. 9.1 [1].

The void fraction ξ is calculated using the area ratios of the gas and liquid phases in the observation area. The void fraction is defined using the following equation suggested by Wojtan et al. [2]:

$$\xi = \frac{N_G}{N_G + N_L}, \quad (3)$$

where N_G and N_L are the total number of gas and liquid phase pixels. The gas and liquid phases were discriminated based on the difference in brightness using MATLAB.

4 Results and Discussion

4.1 Flow Patterns

Four flow patterns were observed in this experiment: bubble, slug, churn, and annular flows. Fig. 3 shows these flow patterns. A bubble flow was observed under high-velocity and low-quality conditions. As a whole, there is a tendency to shift from a slug flow to an annular flow as the quality increases.

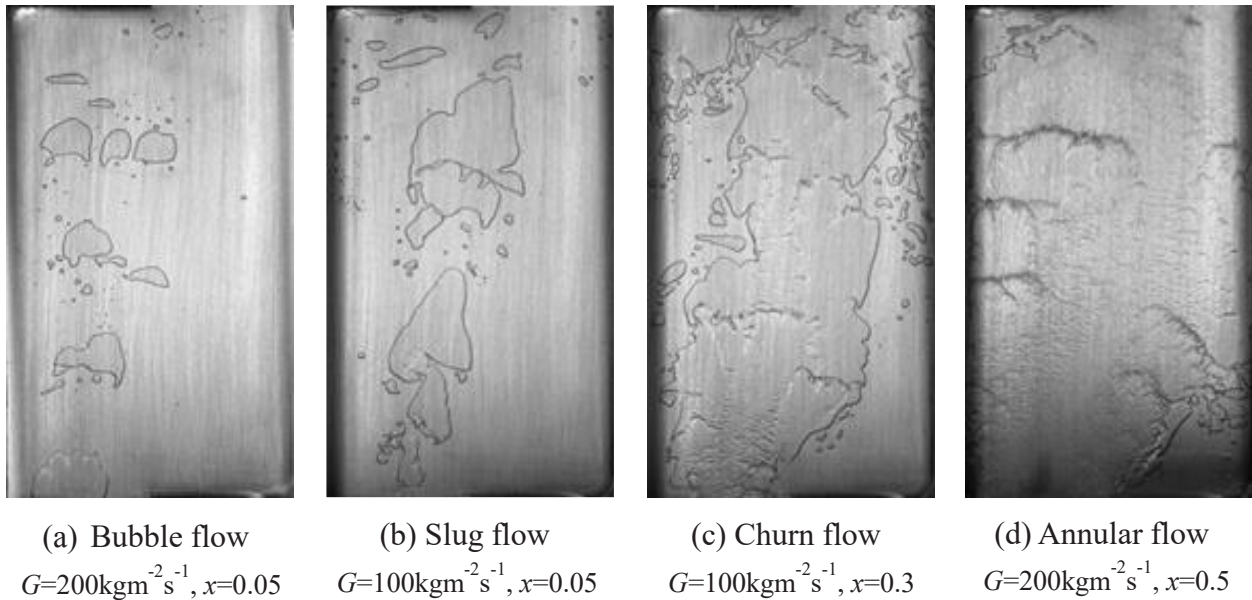

Fig. 3 Typical observations of the two-phase flow patterns

4.2 Void Fraction

Fig. 4 shows an image of a flow pattern and image analysis using MATLAB. The gas phase is in white and the liquid phase is in black.

Fig. 5 shows the relationship between the vapor quality and void fraction of each mass velocity. It can be seen that the measured void fraction increases with an increase in vapor quality and mass velocity. Compared to the two previous correlations of Smith [3] and Huq-Loth [4], the correlations show a good prediction for the condition of the highest mass velocity and a high vapor quality. However, these correlations overpredict the void fraction, and the deviation becomes significant under the lowest mass velocity.

5 Conclusion

This study investigated the flow pattern and void fraction in a narrow rectangular channel. The following conclusions were obtained.

- (1) Bubble, slug, churn, and annular flows were observed.
- (2) The void fraction was greatly affected by the mass velocity, and increased with the increase in vapor quality and mass velocity.
- (3) The previous correlations overpredicted the measured void fraction, which was expected to be $G = 200 \text{ kgm}^{-2}\text{s}^{-1}$.

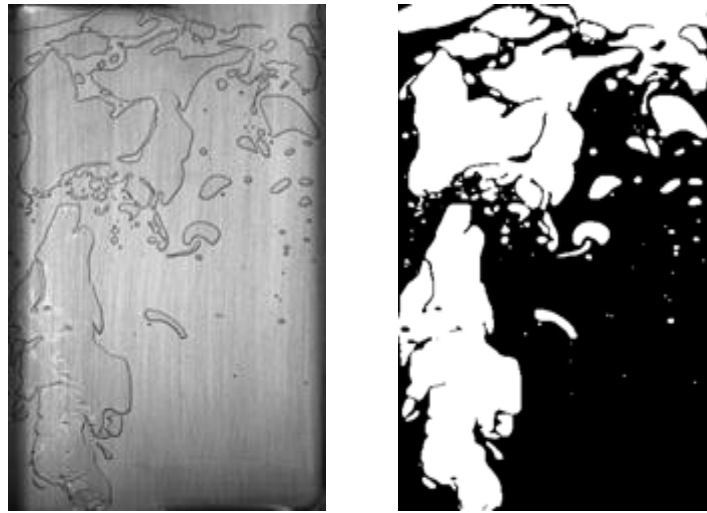

Fig. 4 Photograph and image analysis using MATLAB

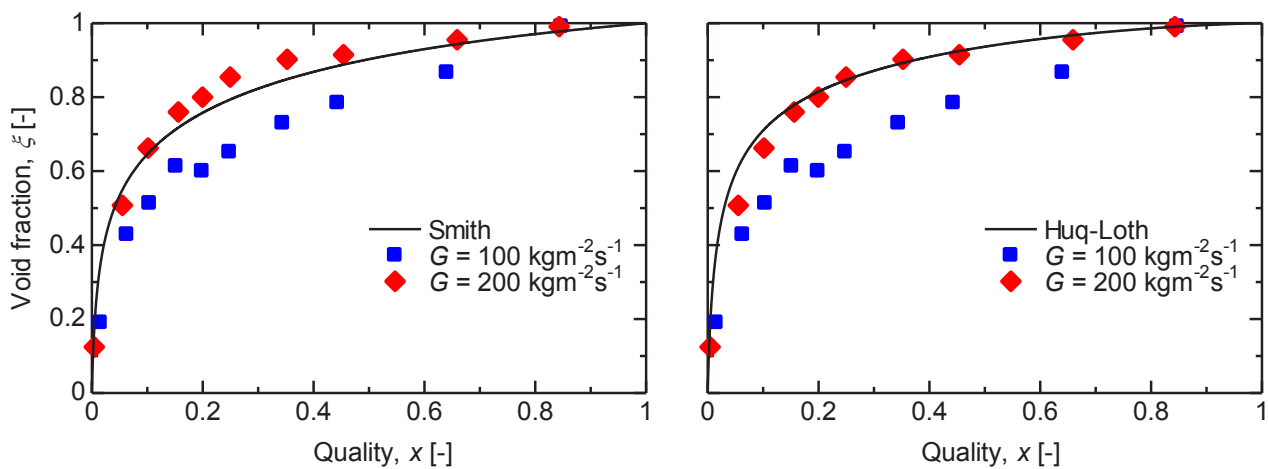

Fig. 5 Comparison between measured void fraction and previous correlations.

6 References

- [1] E.W. Lemmon, M.L. Huber and M.O. McLinden: NIST Standard Reference Database 23, REFPROP Ver. 9.1, (2013).
- [2] L. Wojtan, T. Uresenbacehr, J.R Thome: Investigation of flow boiling in horizontal tubes: Part I-A new diabatic two-phase flow pattern map, International Journal of Heat and Mass Transfer Vol. 48, pp. 2955-2969 (2005).
- [3] S.L. Smith: Void fractions in two phase flow: A correlation based upon an equal velocity head model, Proceedings of the Institute Mechanical Engineers, London, Vol.184, Part 1, No. 36, pp647-657 (1969).
- [4] R. Huq, L. Loth: Analytical two-phase flow void prediction method, Journal of thermophysics and heat transfer Vol. 6.1, pp. 139-144 (1992).